

Fully automated ease with micrometrical accuracy

A magnetic measuring scanner, the Magnetoscan is designed to measure the superficial magnetic induction of permanent magnet devices that exhibit axial or radial multipolar magnetization, as is the case with rotors or stators.

HOW IT WORKS

The Magnetoscan works by rotating and recording the magnetic field versus the angular displacement at a particular level and distance. The measurement is taken by a Hall probe, which is connected to a gaussmeter. The Hall probe is positioned with micrometrical accuracy at every distance from the surface of the sample by a precise mechanical tool with 3 axes. The sample is fixed to the rotating base through a shaft holder chuck; an interchangeable holder allows measurement of the samples with a shaft dimension between 0.5 to 15 mm.

Once the rotor is set on the support and the probe is positioned to the desired distance and height, the measurement is carried out in a fully automated mode. The sample performs a complete revolution (plus approximately 10°) in about 30 seconds, during which the induction is measured and sent to the connected PC, which processes and displays the measured values.

The measurement is fully automated and controlled by a dedicated software program that records 10,000 measurements per revolution, with a resolution accuracy of 0.036° . The software provides many forms of scanned data, including: visualization of diagram angle-induction, peak detection, angular shift, harmonic distortion, and FFT.

CONTROLS THESE PARAMETERS

- Field peak amplitude
- Pole width
- Sinusoidal shape and Total Harmonic Distortion (THD)
- Angular control for skewed rotors
- Peak-to-peak variation and magnetic field slope
- Constancy of the peak amplitudes
- Angular differences between mechanical and magnetic references

STANDARD CONFIGURATION

- Mechanical positioning tool with axes micrometrical controls
- Electrical base, containing DC electrical motor, encoder and all electrical circuits
- Hall probe (model could vary with application)
- Position tool for Hall probe and samples (customized)
- Holder's set: set of holders for different shaft's diameters
- Touch screen for manual settings and visualization of coordinates
- PC and printer
- Instruction manual

TECHNICAL SPECS

GENERAL

Measurable materials	Magnetized devices containing hard magnetic materials
Measurable quantities	B-field profile, FFT
Type of magnetization	Axial and radial multi polar magnetization on 2 or 3 axes
Max sample's weight	5 kg (11 lb)
Axes	X, Z linear, adjustable and measurable (by touch screen); Y linear, adjustable, angular measurable (by touch screen)
Axes ranges	X: 400 mm (15.7"), Y: 100 mm (3.9"); Z: 400 mm (15.7")

MECHANICAL SPECIFICATION

Available shaft holders	from 0.5 to 15 mm (0.02" to 0.59")
Available movement	Longitudinal, lateral and vertical
Linear displacement resolution	1 μ m
Angular resolution	0.036°
Number of data/revolution	10000
Scansion speed	Adjustable (typical: 20 ÷ 30 seconds)

ACQUISITION BOARD

Analog inputs	16, 500 kS/s, 16 bits, +/- 10V
Digital I/O lines	24 DIO, 1 MHz clock rate
Counters/timers	4, 32 bits, 100 MHz

GAUSSMETER (STANDARD MODEL)

Range (resolution)	300 G (0.1 G), 3 kG (1 G), 30 kG (10 G)
Accuracy	\pm 1%
Frequency Bandwidth	DC - 20 kHz
Sampling rate	100 kS/s
Reading	Gauss, Tesla, Amps/meter
Communication port	USB

HALL PROBE (STANDARD MODEL)

Type	Axial
Linearity	0.5% / 30 kG
Active area	0.381 mm (0.15") diameter
Temperature range	0 ÷ 75 °C
Zero stability with temperature	\pm 0.3 G/°C
Calibration stability with T	- 0.05 G/°C
Frequency range	DC to 20 kHz
Stem material	Rigid phenolic

ELECTRICAL MOTOR

Speed	6 round/minute at 24 V
Max power	15 W
Max torque	1500 mN · m (continuous)

PHYSICAL

Power	220 Vac, 50/60 Hz
Dimensions	1000 x 600 x 1200 mm (39.4 x 23.6 x 47.2")
Weight	150 kg (332 lb)

ACCESSORIES

Magnetic zero chamber; set of clamps; key of clamps

MANUALS AND DOCUMENTATION

Instruction manual in English, CE mark,
Calibration certificate



SOFTWARE MS-04

The software MS-04 manages and controls the measurement with Magnetoscan. The software program enables automatic data collection saved to a file. The operator only has to select the parameters prior to the measurement, the MS-04 does the rest. It's also possible to set the rotation speed for the sample, type of magnetization requirement (axial or radial), distance between probe and sample surface, and the number of poles. The software automatically samples the measured data and compares it with the applications set of parameters to provide a complete analysis of the results.

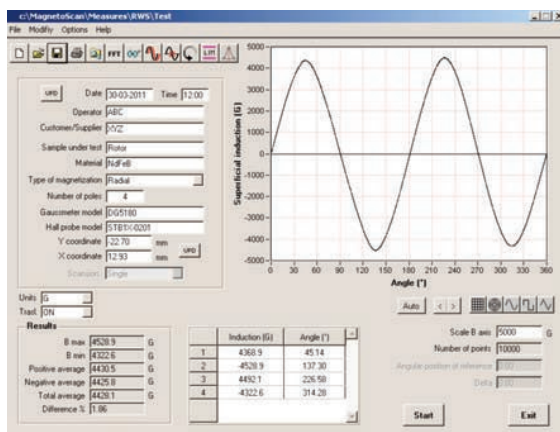

Main Page with parameters set, results and graph

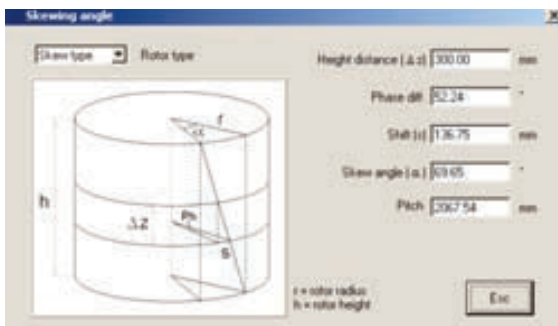

Customizable reports

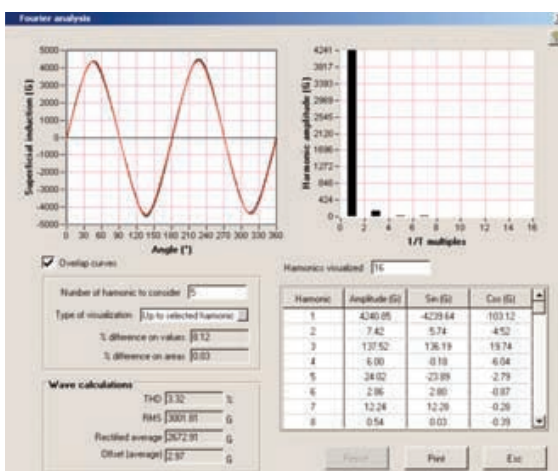

Parameters Settings

Type of measurement

- Superficial Magnetic Induction and H-field profile

Setting of measuring parameters

- Manual or automatic settings of parameters. The final list of parameters is shown in the main page
- Possibility to change graphical parameters, scan speed and calibrate coefficient
- Limit setting, with possibility to have notification on how many poles are in specification
- A mechanical reference can be used to calculate distance between peaks and zero crossings
- Speed setting with the possibility to rotate the sample of an arbitrary angle in CW or CCW sense

Results

- Angle-induction diagram, Bmax, Bmin, positive and negative average, total average angular shift, harmonic distortion, FFT and more advanced results
- Magnetic units in SI and CGS

Data base and file searching

- Data base of measuring files with fast search options, ordering selection, etc.
- Compatible with spreadsheet programs, as Microsoft Excel™

Printing a report

- Print reports containing data and graph, or only a text containing only data
- The report can be opened and saved with other word processor programs, like Microsoft Word™

Data elaboration

- Curve comparison: Fourier Analysis through Fast Fourier Transform (FFT) algorithm
- Math elaboration to calculate parameters such as zero crossing, pole width, slopes, area, etc.
- Two available graphical representation of data: Cartesian graph and Polar graph
- Indication of the angle of mechanical reference (photocell) on the graph and in the parameters
- Poles out of specification are marked in red
- Measure of skew angle

